

Download

Techno India Group App



VER - SB2.0

CENTRAL ADMISSION CELL  
HELP LINES

9836544419  
9836544418  
9836544417  
9836544416  
9836544414  
9836544413  
9836544412  
9836544411  
9836544410



TRIPURA OFFICE

8335061499

PATNA OFFICE

7319871090 / 7319871091

RANCHI OFFICE

7360083495 / 7360083496

9836544406 / 9836544416 / 9836544426

Techno India Campus, LB-10, Salt Lake, Sector - III, Near Chingrighata Crossing, Kolkata - 700098 (beside Leather Technology College)

Techno India (2nd floor), EM 4/1, Salt Lake, Sector - V, Kolkata - 700091, West Bengal, India

Techno India, DN-20, Salt Lake, Sector - V, Near College More, Kolkata - 700091, West Bengal, India

Ranchi Office: ARJAN PLACE (1st Floor) 5, Main Road, Near Over Bridge & Bigbazaar, Beside New India Hotel, Ranchi-834001

Patna Office: Verma Centre (2nd Floor), Boring road Chouraha, Patna, Bihar - 800001.

[www.technoindiagroup.com](http://www.technoindiagroup.com)

[www.technoindiauniversity.ac.in](http://www.technoindiauniversity.ac.in)

[Info@technoindiagroup.com](mailto:Info@technoindiagroup.com)

/tigkolkata

/tiukolkata

/technoindiauniversity

[www.technoindiagroup.com](http://www.technoindiagroup.com)



**TECHNO INDIA GROUP**

*Harnessing Technology, Enriching Lives*

Engineering

Architecture

Pharmacy



# Explore

Techno India Group

## Approvals



## Affiliation



# 41+

## Years

in Academia



Techno India Group is one of Asia's largest and most prestigious educational organizations. Founded in 1985, it has consistently garnered attention for its exceptional faculty, cutting-edge research opportunities, and diverse academic programs. With nearly four decades of academic excellence, the group continues to set high standards in education, emphasizing strong student-faculty relationships. Techno India offers world-class infrastructure, modern technology-enhanced teaching tools, and industry-driven curricula. The institute spans a wide array of disciplines, including Science, Humanities, Commerce, Law, Engineering, Management, Pharmacy, and Architecture, making it one of the most sought-after educational destinations in the country. Through partnerships with esteemed national and international universities, exchange programs, and extensive industry collaborations, Techno India Group is committed to intellectually inspiring its students. The group's mission is to build a better India by equipping the youth with the skills and knowledge necessary to meet the technological challenges of the 21st century.

# ADMISSION PROCEDURE

The admission procedure for various academic programs at Techno India Group involves an intricate screening process that ensures the selection of the brightest students across the globe. Admission here is ensured through various national and international entrance examinations. Aspiring candidates can also appear for TNJEE (Techno India National Joint Entrance Examination) as a possible pathway to securing admission.

Apply online @ [www.technoindiagroup.com](http://www.technoindiagroup.com) / [www.technoindiauniversity.ac.in](http://www.technoindiauniversity.ac.in)

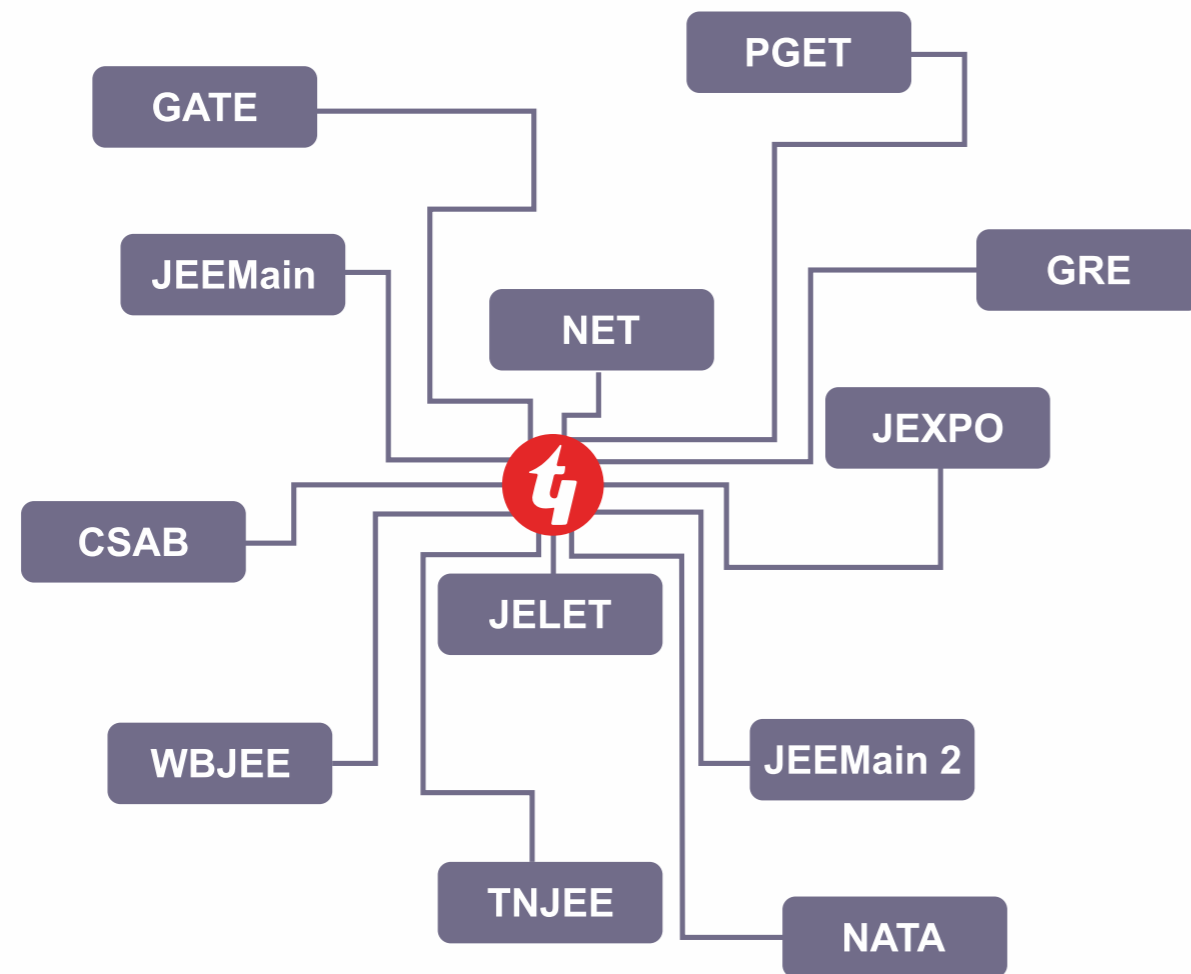

**Disclaimer:-** Techno India Group does not solicit student admissions through any external sources



## WHY ENGINEERING: TRANSFORMING FROM INDUSTRY 3.0 TO 4.0

Technological innovations, driven by engineering solutions, have significantly enhanced our quality of life and strengthened the global economy. Take Uber, for example: it has revolutionized daily transportation by eliminating the challenges people once faced, offering a seamless travel experience through a network of well-maintained cabs—all without owning a single vehicle, thanks to cutting-edge technology.

Since its inception, Techno India has championed hands-on training, believing that true understanding comes from deeply engaging with subjects from the ground up. Only by thoroughly exploring concepts can groundbreaking technologies be envisioned.

This philosophy is evident in the numerous interdisciplinary projects undertaken by our students and faculty. A prime example is the ambitious project by the Civil Engineering and Architecture departments to construct a two-story airport and an underground tunnel beneath the Ganges River. Other noteworthy initiatives include collaborative research between the Biotechnology, Microbiology, and Food Technology departments on alternative protein sources, the ECE and BME departments' advancements in medical equipment, and the CSE and BME departments' work on imaging technologies.

Currently, the ECE department is working on automation and robotics projects in partnership with the ME and EE departments, while the AEIE department collaborates with the EE department on power grid technology and power source design.

In a world where innovations occur every minute, we at Techno India ensure our students are always ahead of the curve!



### Engineering & Re-engineering

Techno India gives a strong emphasis on **Re-engineering**: envisioning a better future using the “**refine and reform**” strategy. Engineering students are trained to restructure, remodel and refurbish existing and conventional methodologies with a grand vision of creating something anew. Innovation & research are the stepping stones of effective engineering: hands-on-training constitutes a major part of the academic experience here. Inculcating the “can do-will do” attitude, skilled mentors here encourage students to develop hybrid technologies which hold promising prospects in the decades to come.



In today's technological era, "computer science" is a term known in nearly every household, with groundbreaking innovations and cutting-edge new technology emerging almost daily. From having groceries delivered to your door and browsing restaurant ratings to shopping for clothes online, booking movie tickets in your favourite seats, ordering delicious meals from home, and accessing digital libraries and online lectures—apps and emerging technology have undeniably made life more convenient and enjoyable.

The reach of computer science is vast, and we've only just begun to explore its potential. Opportunities abound for those aspiring to a career in this dynamic field.

At Techno India Group, we offer a wealth of prospects for tech professionals, developers, and computer scientists—from working in top MNCs on corporate projects to engaging in impactful research that benefits society. Our industrial internships at leading organizations provide students with global exposure while sharpening their technical and analytical skills. Moreover, Techno India offers comprehensive grooming classes to prepare students for exams like GRE, GATE, TOEFL, and IELTS—exams that open doors to studying and working abroad with attractive salaries.

*Discover your inner techie and transform the world around you!*

### Courses Offered

- After Class XII - B.Tech [4 years], Dual B.Tech-M.Tech
- After Diploma / B.Sc - B.Tech (L) [3 years]
- After Graduation - M-Tech [2 years]
- After Post Graduation - Ph.D

*"In a world that's increasingly run on technology, computer science is a liberal art that every student should be exposed to regardless of their path in life."*

*-Hadi Partovi*

```
day = datetime.datetime.now(),today()
res = []
include_this_month:
# get next month's data with:
next_month = today.replace(day=28) + datetime.timedelta(days=1)
# use next month's data to get this month's data breakdown
start, end = get_last_month_data(next_month)
dates.insert(0, {
    "start": start.timestamp(),
    "end": end.timestamp(),
    "start_json": start.isoformat(),
    "end": end.timestamp(),
    "end_json": end.isoformat(),
    "timesince": 0,
    "year": start.year,
    "month": str(start.strftime("%B")),
})
```

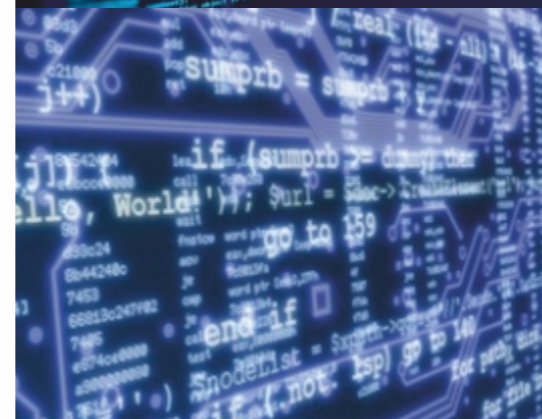

## ELECTRONICS & Communication Engineering

*"Engineering turns ideas into reality, bridging the gap between what is and what could be."*

The evolution of the computer age has amplified the importance of Electronics and Communication Engineering (ECE) in our daily lives. From designing smartphones and smart TVs to developing computers, pocket radios, and advanced satellites, the impact of ECE is undeniable. With its seamless integration into fields like Computer Science, Instrumentation, and Healthcare, the scope of ECE has expanded dramatically over the past few decades.

*The advent of self-driving cars, smart energy systems, robotics, and drones would be unimaginable without the advancements in ECE!*

For ECE aspirants, the opportunities are vast and varied. From roles in private and government sectors to careers in telecommunications, IT, mobile communication, and power electronics, this engineering discipline offers some of the most promising prospects in today's world.

At Techno India Group, students gain hands-on experience through internships at leading MNCs, allowing them to delve deeper into this dynamic field. Recognizing the importance of global communication, the institute emphasizes proficiency in international languages like French and Spanish, opening doors for students to pursue higher studies in Europe and the Americas. Exams such as GRE, GATE, TOEFL, and IELTS further unlock opportunities for those aiming to settle abroad with competitive salaries.

Techno India is currently spearheading a groundbreaking initiative that integrates Medical Science with Electronics and Communication Engineering. By leveraging state-of-the-art technologies, this project aims to enhance medical equipment. Eminent doctors and skilled professionals, including Professor Sukumar Mukherjee from Calcutta Medical Hospital's Department of Medicine, are actively involved in this widely recognized effort.

### Courses Offered

- After Class XII - B.Tech [4 years] | After Diploma / B.Sc - B.Tech (L) [3 years] | After Graduation - M-Tech [2 years] | After Post Graduation - Ph.D
- Dual B.Tech-M.Tech

## ELECTRONIC AND COMPUTER SCIENCE

Electronics and Computer Science (ECS) is at the core of technological progress. From smartphones to satellites, ECS powers the systems that define modern life. This field not only shapes the present but also drives the future, integrating with sectors like Artificial Intelligence, Robotics, and Biomedical Engineering.

As we enter an era of smart cities, autonomous systems, and quantum computing, ECS becomes even more crucial. The opportunities are vast, with careers in software development, telecommunications, cybersecurity, and renewable energy. ECS professionals are highly sought after for their ability to innovate and solve complex challenges.

At Techno India Group, ECS students gain cutting-edge skills through a curriculum that balances theory with practical experience. Internships with global companies prepare students for future challenges. The institute also focuses on global readiness, with language training and exam preparation for GRE, GATE, TOEFL, and IELTS, paving the way for international education and careers.

Techno India is leading an initiative that combines ECS with Environmental Science to develop sustainable technologies. This collaboration with industry experts and academic leaders aims to make a significant impact on technology and society.

### Courses Offered

- After Class XII - B.Tech [4 years] | After Diploma / B.Sc - B.Tech (L) [3 years] | After Graduation - M-Tech [2 years] | After Post Graduation - Ph.D
- Dual B.Tech-M.Tech

# COMPUTER SCIENCE ENGINEERING - Artificial Intelligence & Machine Learning CSE - AIML

*"Artificial Intelligence is not just a tool; it's the gateway to a future where machines amplify human potential and imagination."*

Artificial Intelligence (AI) has become an essential part of the technology we use in our daily lives. When combined with Computer Science, it becomes a powerful force shaping the future. Whether it's driving to the office, finding a restaurant, staying informed, or receiving personalized recommendations on social media, AI—integrated with Computer Science—plays a pivotal role. Techno India Group is proud to announce that we had hosted the first robo-citizen of the world, Sophia, developed by Hanson Robotics, at our campus. Such unique opportunities of interaction, along with placements at leading software companies are a daily affair at Techno India Group.

As AI continues to grow in importance, so does the need for researchers to develop and refine these technologies. At Techno India, we specialize in cutting-edge fields like Cloud Computing, IoT, 5G technology, and blockchain. We provide students with unique opportunities to master the experimental and foundational aspects of Machine Learning and AI. In this rapidly evolving field, a wide array of courses offers the chance to make a meaningful and lasting impact on the world.

Techno India Group is proud to have hosted Sophia, the world's first robot citizen developed by Hanson Robotics, at our campus. Such unique interactions, along with placement opportunities at leading software companies, are a regular part of the Techno India experience.

## Courses Offered

After Class XII - B.Tech [4 years]  
After Graduation - M-Tech [2 years]



## Courses Offered

After Class XII - B.Tech [4 years]  
After Graduation - M-Tech [2 years]

# CSE-D.Sc



# COMPUTER SCIENCE ENGINEERING - DATA SCIENCE

*"The goal is to turn data into information, and information into insight." – Carly Fiorina, former CEO of Hewlett-Packard*

This Engineering program at Techno India Group uniquely combines technology, basic science, and computer applications with cutting-edge industry practices. Accredited by AICTE, the program offers a dynamic learning environment that blends theoretical knowledge with practical experience.

Students benefit from state-of-the-art laboratory facilities and work closely with distinguished professors on real-world projects. This approach develops critical problem-solving skills and prepares students for the evolving demands of the tech industry.

The comprehensive curriculum spans from BTech to PhD, covering essential areas such as Database Management Systems, Cloud Computing, Networks and Security, Programming, and Operating Systems. Through hands-on training and professional development courses, students are equipped to excel in various computer science-oriented roles, whether in leading tech companies or multinational corporations.

Techno India Group's program not only imparts technical knowledge but also nurtures adaptability and innovation, ensuring graduates are well-prepared for the challenges of the ever-changing tech landscape.

*“Electrical Science has disclosed to us the more intimate relation existing between widely different forces and phenomena and has thus led us to a more complete comprehension of Nature and its many manifestations to our senses.”- Nikola Tesla*

Living in the 21st century, Electrical Engineering is the “cornerstone and driver of innovation of the devices we utilize daily to improve our quality of life”. From the invention of telegraph to wireless devices, from wireless systems to power and energy systems, from 3D printers to prosthetics, EE has undoubtedly simplified our lives to a great extent.

*“Electrical engineering: powering the pulse of progress”*

Being one of the core branches of engineering, EE provides a broad range of career prospects at leading core and software companies. Students at Techno India Group get ample opportunities to attend international conferences, seminars and workshops at prestigious institutes and internships at premier MNCs. Owing to a sound grasp of the subject fundamentals, many also pursue higher studies overseas in a broad range of interdisciplinary specializations, including but not limited to, Automation and Control, Aerospace Engineering, Communication Engineering, Power Engineering and Computer Science.

### Courses Offered

- After Class XII - B.Tech [4 years], Dual B.Tech-M.Tech
- After Diploma / B.Sc - B.Tech (L) [3 years]
- After Graduation - M-Tech [2 years]
- After Post Graduation - Ph.D

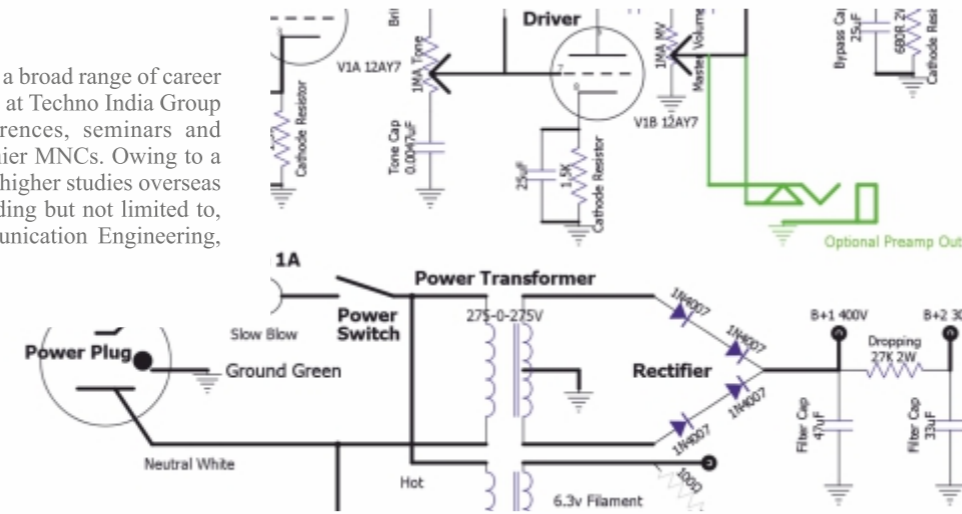

# Electrical Engineering (EE)



*“The number one benefit of information technology is that it empowers people to do what they want to do. It lets people be creative. It lets people be productive...” - Steve Ballmer*

The role of Information Technology in today's society is undeniable; IT has crept into every sphere of the society including Business, Education, Finance and Health care. One of the most robust industries in the world, IT industry has had a pronounced impact on the growth and employment ratio of the nation and it stands as the key driver of global economic growth of the country.

*“We're changing the world with technology.” - Bill Gates*

Techno India Group offers its students a diverse range of opportunities to work in premier MNCs as IT specialists, network administrators, database administrators etc. Internships at industries provide students with the chance of sharpening their technical and analytical skills. Pursuing M.Tech and MS at reputed foreign universities is a dream harbored by many aspirants here and actualized by almost all. Clearing examinations such as GRE, GATE, TOEFL, IELTS enable students to study and settle abroad with attractive pay packages. TIG students get the incredible opportunity to work on research projects as JRFs and SRFs in elite institutes. Research enthusiasts even go on to complete their post-doctoral education in leading academic institutes.

### Courses Offered

- After Class XII - B.Tech [4 years] | After Diploma / B.Sc - B.Tech (L) [3 years] | After Graduation - M-Tech [2 years] | After Post Graduation - Ph.D
- Dual B.Tech-M.Tech

*“Electronics and electrical engineering have transformed our world, powering innovation and shaping the future.” - Elon Musk*

Techno India Group's Electrical & Electronics Engineering course offers an exceptional academic program that prepares students for a dynamic career in the field. With a strong emphasis on practical knowledge and industry-relevant skills, the course equips students with a deep understanding of electrical circuits, electronics, power systems, and control systems. The program features a comprehensive curriculum that blends theoretical concepts with hands-on training, ensuring students are well-equipped to tackle real-world challenges. Techno India Group's state-of-the-art laboratories and research facilities provide students with ample opportunities to experiment and innovate. Additionally, the course fosters critical thinking, problem-solving abilities, and effective communication skills, preparing graduates to become competent professionals in various domains. The faculty comprises experienced industry experts and academicians who provide mentorship and guidance throughout the program. By pursuing the Electrical & Electronics Engineering course at Techno India Group, students gain a solid foundation and open doors to exciting career prospects in sectors such as power systems, telecommunications, robotics, automation, and renewable energy.



# Electrical & Electronics Engineering (EEE)

### Courses Offered

- After Class XII - B.Tech [4 years]
- After Graduation - M-Tech [2 years]
- After Post Graduation - Ph.D



# CSE CYBER SECURITY

A degree in Cyber Security will enable you to better navigate the new and emerging career pathways that are arising from the newer applications of computer science engineering to the variegated fields of human activity. In contemporary times, the questions of data security, data privacy and ease of making online transactions have necessitated the growth of roles for cyber security experts in various private, government, fintech, security and service-based organisations. In this course, you will learn how to perform penetration testing, identify vulnerabilities and create your own systems for security purposes to solve issues relating to the data privacy of organisations and individuals. This course is designed keeping in mind the skill-requirements of the world of tomorrow. With the rise of blockchain, cryptocurrencies and non-traditional financial pathways the need for cyber security experts will only increase in the days to come and the syllabus, structure and evaluative procedures of the course reflect this.

## Courses Offered

After Class XII - B.Tech [4 years]  
After Graduation - M-Tech [2 years]

# CIVIL ENGINEERING (CE) WITH AI

*“My buildings will be my legacy. They will speak for me, long after I’m gone!” - Jullia Morgan*

Civil Engineering is a core branch of engineering that deals with “planning, designing, constructing, maintaining, and operating infrastructures while protecting the public and environmental health as well as improving existing infrastructure.” From the construction of multi storied buildings to runways, earthquake resistant residences to compact apartments, historic wonders such as Taj Mahal, the Great Wall of China to modern masterpieces such as London Bridge and Howrah Bridge: none of this would have been possible without Civil Engineers!

*“We shape our buildings; thereafter they shape us.”-Winston Churchill*

Techno India Group provides an abundance of internship opportunities for CE aspirants; exposure to corporate assignments in industries strengthens their design expertise. Majority of the students here harbor the desire to pursue M.Tech, MS and eventually, PhD and post-doctoral programs to contribute to global development and research. Proficiency in foreign languages such as French and Spanish enables students to earn scholarships overseas.

Techno India is currently heading two visionary projects in collaboration with the Civil Engineering and Architecture departments: construction of a two storied airport and an underground tube tunnel connecting the banks of the river Ganges. Endeavors such as these bear testament, time and again, to the unwavering quest of this elite group in proving its mettle.

## Courses Offered

After Class XII - B.Tech [4 years] - Dual B.Tech-M.Tech	After Diploma / B.Sc - B.Tech (L) [3 years]	After Graduation - M-Tech [2 years]	After Post Graduation - Ph.D
---	--	--	---------------------------------

## APPLIED ELECTRONICS & INSTRUMENTATION ENGINEERING (AEIE)

The primary focus of Applied Electronics and Instrumentation engineering is the “development and implementation of electrical and electronic instruments for the purpose of measuring, monitoring, and recording physical phenomena”. Design and configuration of automated systems is at the root of AEIE.

Techno India Group firmly believes in implementation-oriented proficiency besides theoretical competence. An abundance of internship opportunities, workshops and seminars encourage students to explore prestigious job profiles in premier MNCs. A majority of aspirants harbor the desire to pursue M.Tech, ME, MS and doctorate programs abroad. Specialization in Control Systems holds a promising future for students in this field.

Pursuing MBA is also a viable option for engineers if they wish to explore the business or operational side of the trade. The Engineering-Management combination goes a long way in shaping the journey of aspirants as it opens a plethora of higher job profiles for them.

## Courses Offered

After Class XII - B.Tech [4 years], Dual B.Tech-M.Tech  
After Diploma / B.Sc - B.Tech (L) [3 years]  
After Graduation - M-Tech [2 years]  
After Post Graduation - Ph.D

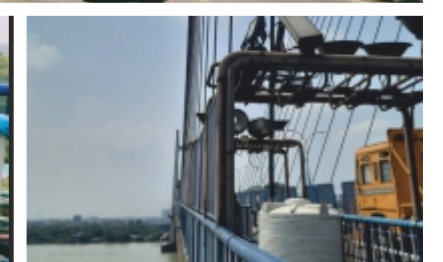
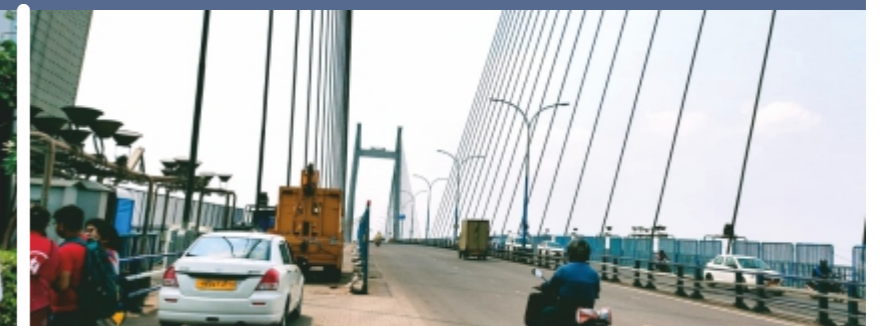
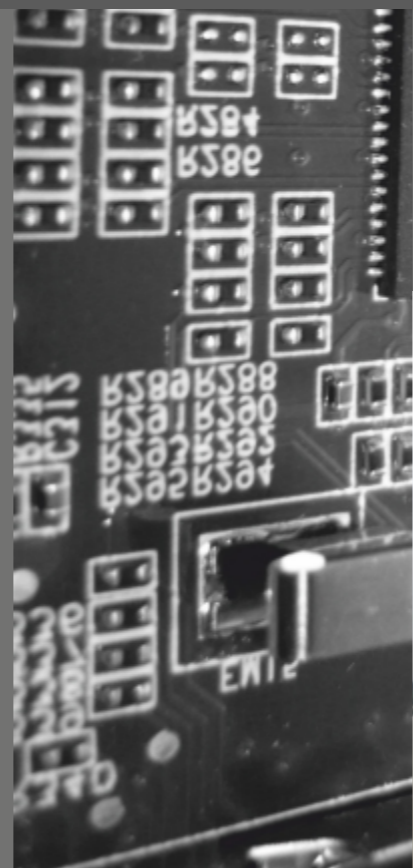



**MECHANICAL**  **WITH AI TO MEET THE REQUIREMENTS OF INDUSTRY 4.0**  
Engineering

*“You can create some soul out of something that’s electronic or mechanical.” - Brendon Urie*

A core branch of engineering, Mechanical Engineering is present everywhere; from the fan above us to our residence, from switches to electronic appliances, from television to smart LEDs - Mechanical Engineering has applications galore. Including core areas such as Mechanics, Dynamics and Thermodynamics, ME has overlaps with Aerospace Engineering, Metallurgical Engineering, Civil Engineering and Electrical Engineering.

*From the construction of battleships to Boeing flights, Mechanical Engineering is everywhere around us!*

Techno India Group (TIG) offers premier internships and hands-on Mechanical Engineering workshops, preparing students for industry demands. Our exceptional placement record and alumni success in reputed organizations speak to the program's quality. Many students engage in innovative research, advancing the field of Mechanical Engineering. TIG's comprehensive approach enables graduates to pursue advanced degrees worldwide, fostering a culture of continuous learning and global excellence in engineering education.

**Courses Offered**

- |   |  |  |                                 |
|---|--|--|---------------------------------|
| After Class XII<br>- B.Tech [4 years]<br>- Dual B.Tech-M.Tech | After Diploma / B.Sc<br>- B.Tech (L) [3 years] | After Graduation<br>- M-Tech [2 years] | After Post Graduation<br>- Ph.D |
|---|--|--|---------------------------------|



**SMART BIO-ENGINEERING**  
**Biotechnology (Bio-Tech)**

*“I think the biggest innovations of the 21st century will be at the intersection of biology and technology. A new era is beginning.” - Steve Jobs*

Research is the foundation of innovation. Techno India Group encourages revolutionary research contributions in the field of Biotechnology: production of food items that can be consumed by patients with a history of medical illness such as diabetes and cholesterol, increasing usage of ayurvedic medicines, herbal cosmetics as well as utilizing insect protein instead of animal protein to add a high nutritional value to the daily food consumption.

This department is also involved with a number of interdisciplinary projects in collaboration with the Microbiology Department at TIG. One such endeavor has been the establishment of the Biotechnology Research Park. Following in the footsteps of the “Go Green” mission, research scholars and eminent faculty members here have devised an eco-friendly initiative. The roof top of Techno India University campus presently houses several agricultural beds which are regularly catered to, leading to the growth of nutrient-bearing fruits and vegetables.

**Courses Offered**

- After Class XII - B.Tech [4 years], Dual B.Tech-M.Tech
- After Diploma / B.Sc - B.Tech (L) [3 years]
- After Graduation - M-Tech [2 years]
- After Post Graduation - Ph.D

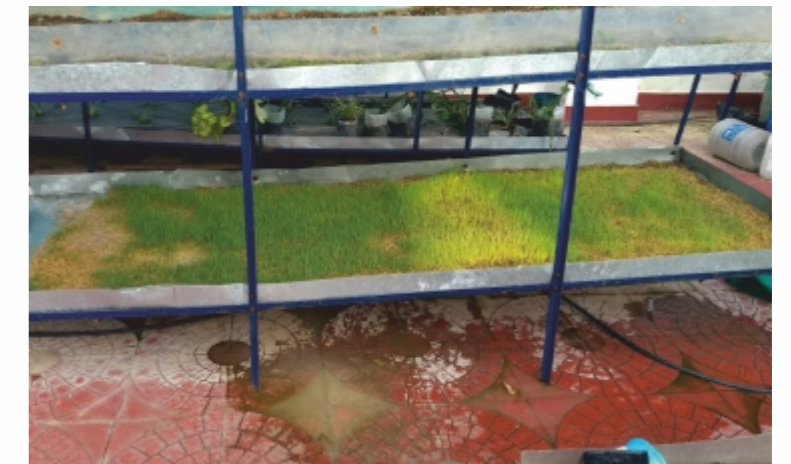



*"IoT has the potential to change the world, just as the Internet did. Maybe even more so." - Kevin Ashton,*

Techno India Group offers an exceptional Engineering IoT course that equips students with the skills and knowledge to thrive in the ever-expanding world of the Internet of Things (IoT). With a comprehensive curriculum and state-of-the-art facilities, the program empowers aspiring engineers to harness the potential of interconnected devices and emerging technologies. Techno India Group's course enables students to grasp the core concepts of IoT, such as sensor integration, data analytics, cloud computing, and cybersecurity. Through practical projects and industry collaborations, students gain hands-on experience in designing and implementing IoT solutions. By undertaking the Engineering IoT course at Techno India Group, students embark on a transformative educational journey that empowers them to shape the future with innovative IoT applications and pave the way for a more connected and efficient world.

#### Courses Offered

- After Class XII - B.Tech [4 years]]
- After Graduation - M-Tech [2 years]
- After Post Graduation - Ph.D

"Agriculture is our wisest pursuit, because it will in the end contribute most to real wealth, good morals & happiness." - Thomas Jefferson

### Smart Agriculture

Agricultural Engineering is an evolving landmark in the field of engineering which is centered around the construction, design and improvement of farming equipment and machinery through technology, artificial intelligence and breakthroughs in making the farming process more efficient and effortless.

At Techno India Group, the Agricultural engineers are trained to integrate technology with farming, in sowing, cleaning and harvesting, in addition to decapitating pests. The variety and rigour of the courses offered here train the individuals to make innovative decisions and take immediate action upon facing a problem.

Techno India also specialises in addressing the problems of today, as this branch allows the students to have sufficient output to help both themselves and the section of farmers who cannot implement technology to better their produce in their fields. It is also a handy tool to provide engineering solutions to control the pollution at large farms which might be an environmental hazard.

#### AE Courses Offered

- After Class XII - B.Tech [4 years]
- After Graduation - M-Tech [2 years]

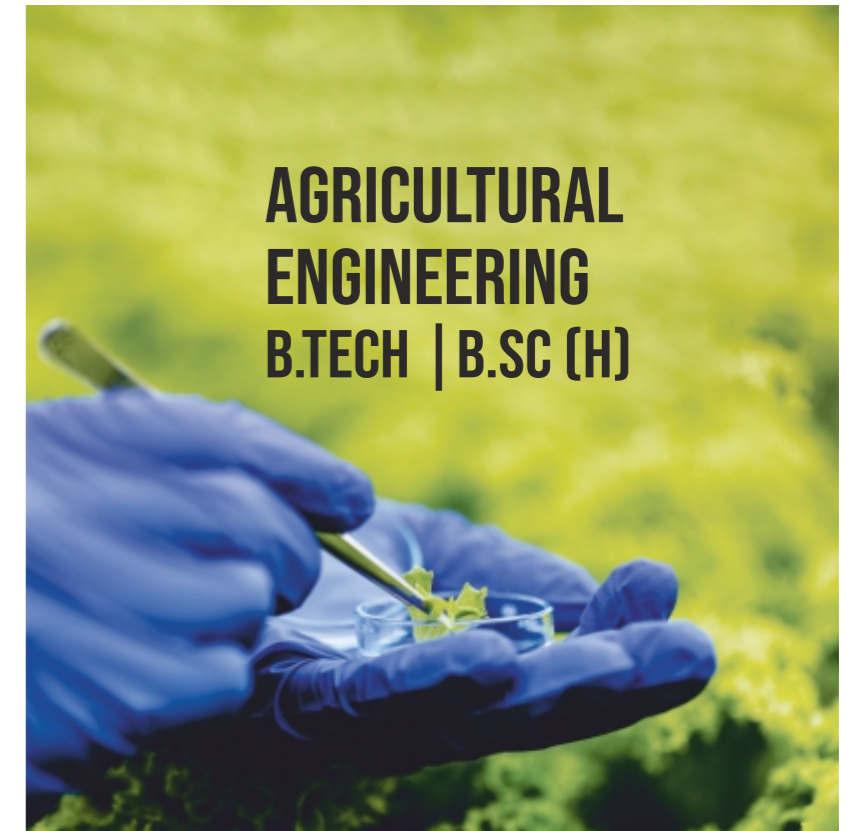

## AGRICULTURAL ENGINEERING B.TECH | B.SC (H)

### Food Technology (FT)

*"Each and every member of the food industry, from farm to fork, must create a culture where food safety and nutrition is paramount."- Bill Marler, Food Safety Attorney, Advocate*

On account of food having a direct bearing on human health, food technology is one of the most promising branches of engineering. The existence of human civilization heavily relies on food scientists and technologists. Food technologists are involved in food processing and production: from developing nutritious foods and impacting human health and safety.

Techno India Group has been recognized for its excellence in Food Technology department by **TIFAC, Dept. of Science & Technology**. Being established as a **Centre of Relevance and Excellence (CORE)**, Techno India has arrested considerable attention from academicians and scholars worldwide. JRFs, SRFs and faculty members of this department have been working meticulously to contribute significantly to global research and development.

#### Courses Offered

- |   |  |
|---|--|
| After Class XII<br>- B.Tech [4 years]<br>- Dual B.Tech-M.Tech | After Diploma / B.Sc<br>- B.Tech (L) [3 years] |
| After Graduation<br>- M-Tech [2 years]                        | After Post Graduation<br>- Ph.D                |



# COMPUTER SCIENCE & BUSINESS SYSTEMS (CSBS)

## in Collaboration with TATA Consultancy Services (TCS)



### Courses Offered

After Class XII - B.Tech [4 years]

TCS along with Techno India University, West Bengal has launched an Undergraduate Engineering course—Computer Science and Business Systems (CSBS). To meet the current industry needs, TCS introduced new courses in Computer Science programmes. It resulted in a 4-year B.Tech course in CSBS and the curriculum has been approved by the Executive Council of AICTE. This course specifically meets the present day industry needs. The curriculum has been specially developed by TCS keeping in mind the rules of UGC. Besides Computer Science, the industry also requires knowledge pertaining to humanities, management, human values, analytical skills, Internet of Things (IoT) etc. This course will instill all the attributes of modern day computing among the students who enroll in this course.

## Biomedical Engineering (BME)

*“The benefits of biomedical progress are obvious, clear and powerful.” - Leon Kass*

The ability of biomedical engineers, with knowledge of both engineering and health sciences, to contribute to the greatest humanitarian challenges of our time rests on two pillars: awareness and engagement. The integration of engineering principles to the fields of biology and healthcare helps develop equipments and devices that can alleviate human suffering to a considerable extent.

Encouraging prodigious innovations has been one of the prime objectives of Techno India ever since its inception. TIG is presently working on a noble interdisciplinary project: **enhancement of medical equipments** to benefit society at large. Elite doctors from reputed hospitals and prestigious medical institutes as well as faculty members and research scholars from the departments of BME and ECE are involved in this grand endeavor.

### Courses Offered

After Class XII - B.Tech [4 years] - Dual B.Tech-M.Tech	After Diploma / B.Sc - B.Tech (L) [3 years]	After Graduation - M-Tech [2 years]	After Post Graduation - Ph.D
---	--	--	---------------------------------

### RESEARCH & GRANTS

At Techno India University, the question "Why?" is central to our research, guiding us to explore techniques that solve complex problems. We focus on future-oriented research, looking 30 to 40 years ahead to anticipate and prepare for what's to come. We are dedicated to developing innovative solutions that tackle both current and emerging challenges, with a focus on long-lasting impact. By fostering an environment grounded in time, space, and action, we strive to make the seemingly impossible achievable. Our emphasis on application-based, interdisciplinary research ensures holistic solutions that address grassroots issues. We also align our research with technological advancements and economic policies, making our work both relevant and impactful.

### Research Grants

On account of the exceptional research endeavors, Techno India Group has been granted research grants by ISRO, DRDO and DST. Our postgraduate students and research scholars are getting the opportunity to work in government projects, using latest technologies and equipments, which have provided them a wide platform for their future. Procurement of such prestigious research funds has significantly improved the quality of research work carried out here, thus enhancing their level of confidence, motivation and interest.

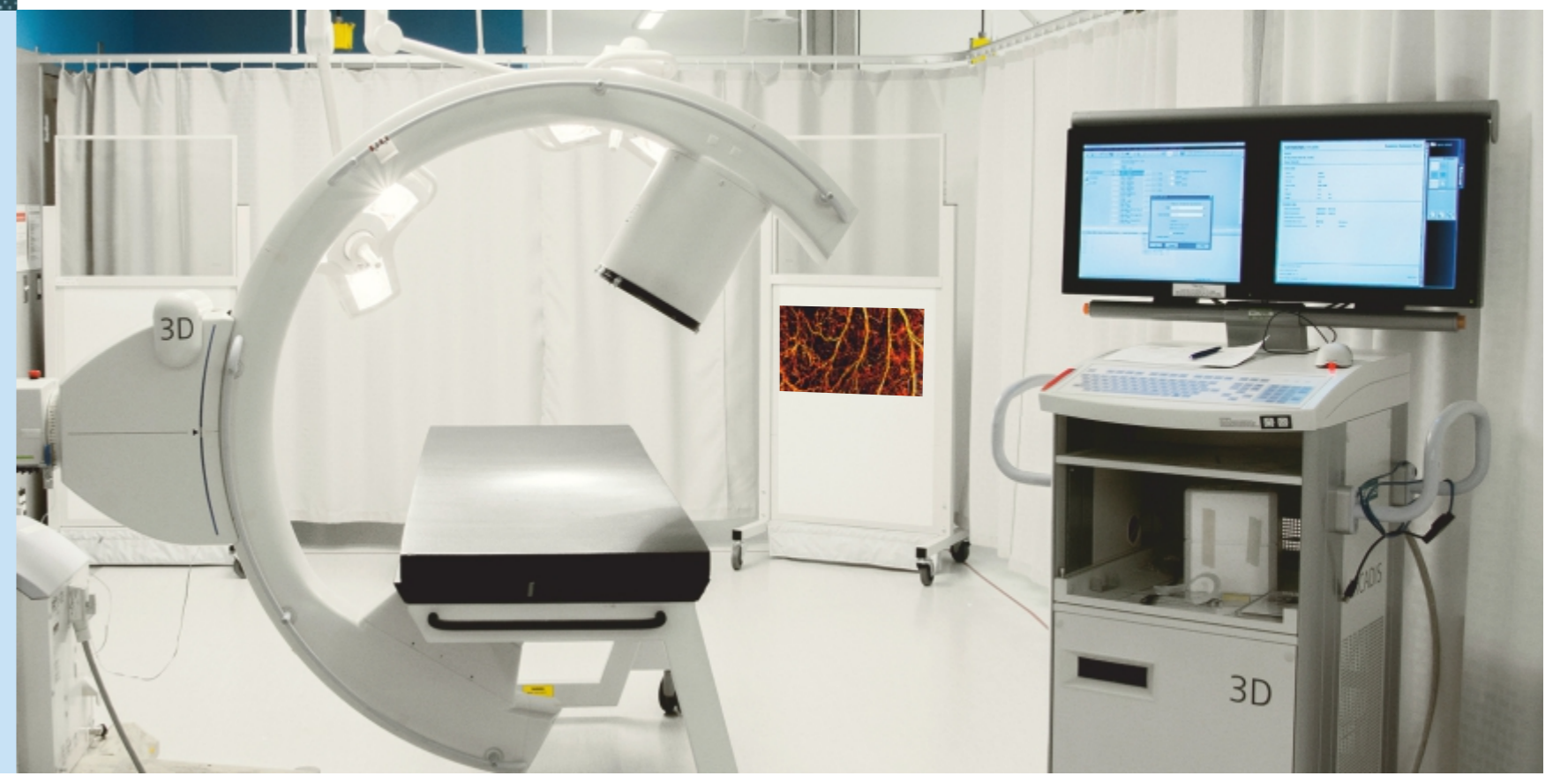



# ARCHITECTURE

## UTILISATION OF AI IN DESIGN

*“Architecture is a visual art and the buildings speak for themselves.” - Julia Morgan*

“Architecture is the art and science of designing and building large structures”. Architecture has been the foundation of human civilization, enduring and outliving generations since the advent of time. Perceived as “works of art”, the rudimentary essence of architecture is innovation and planning.

Techno India Group has always been on the forefront of innovation and progress right from the start. Encouraging students to be involved in hands-on training-oriented workshops and projects, and motivating students to pursue higher studies has been the prime objective of TIG. One of the many endeavors of this group has been the inception of Botol Bari- yet another environment conscious initiative, keeping nature preservation and the “reduce, reuse and recycle” paradigm in forethought. Construction of compact apartments spread across a small area, and a natural disaster resistant residential complex are a few of the upcoming projects undertaken by the Architecture Department of TIG.

### Courses Offered

- |  |   |  |
|--|---|--|
| <p><b>After Class XII</b><br/>- B.Arch [5 years]</p> | <p><b>After Graduation</b><br/>- M-Arch [2 years]</p> | <p><b>After Post Graduation</b><br/>- Ph.D</p> |
|--|---|--|

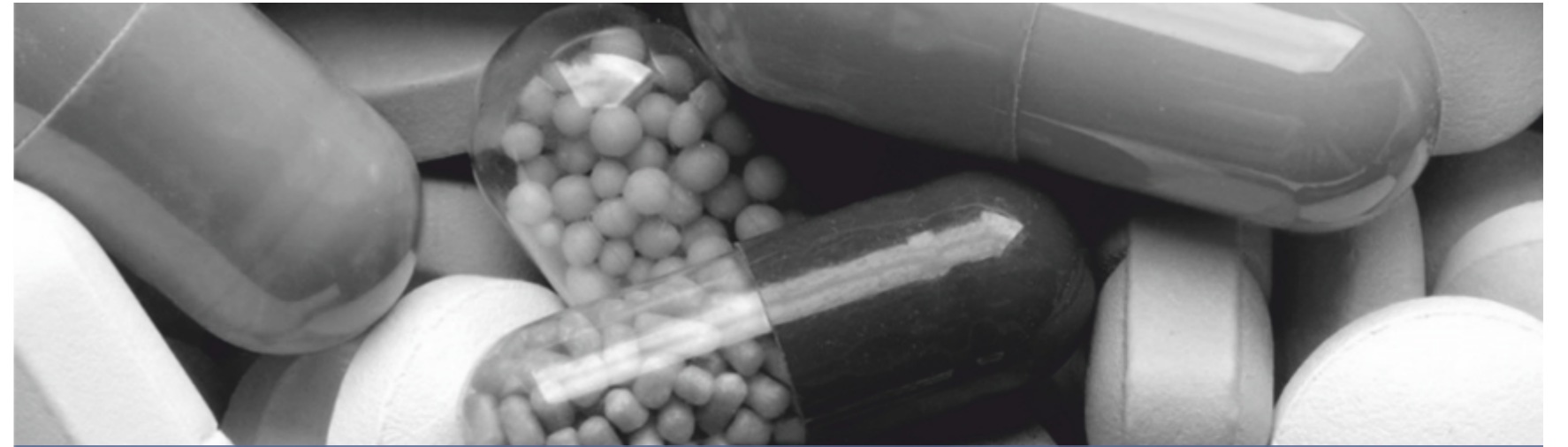
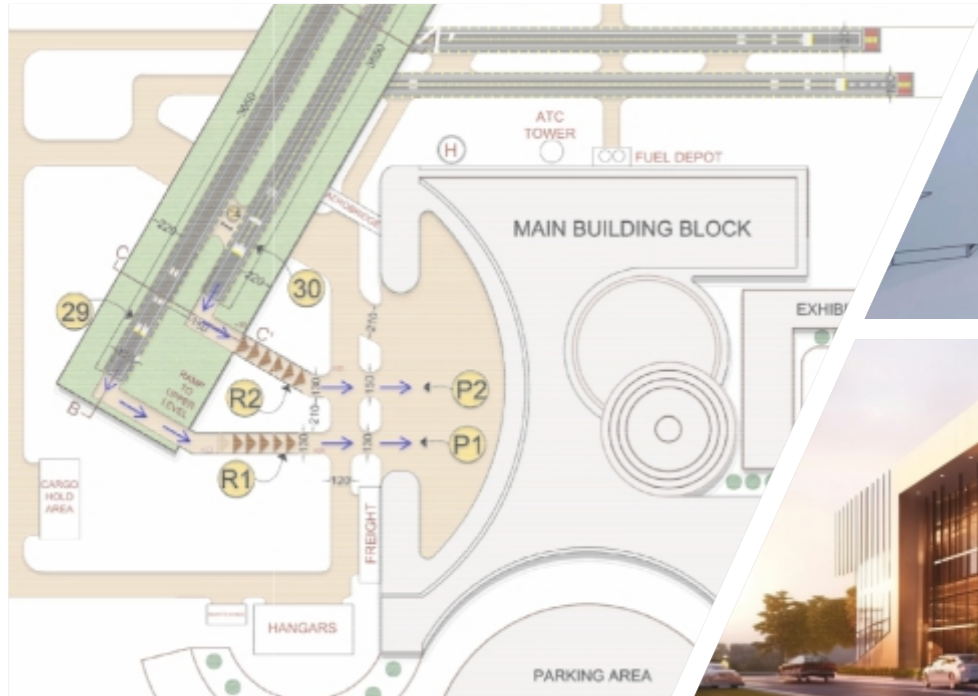

## Pharmacy Gen-Next Medicine

“It is easy to get a thousand prescriptions but hard to get one single remedy.”

The pharmaceutical industry is the future of human civilization; the population boom has been accompanied by an increasing need to feed an ever growing population. The advent of technologies has in no way dented the possibility of terminal and fatal diseases-they still continue to threaten our existence. This is where Pharmacy plays the most pivotal role.

Techno India Group encourages students to delve into visionary research methodologies that hold a promising future for decades to come. Encouraging aspirants to pursue ME/MS/M.Tech/PhD in top-ranked national and international universities broadens their vision and deepens their research insight and expertise. There is an abundance of projects being undertaken by the Pharmacy Department of Techno India Group; developing vaccines and medicines that fight against life threatening diseases is the long term vision of this institute.

### Courses Offered

- |   |  |  |
|---|--|--|
| <p><b>After Class XII</b><br/>- B.Pharm [4 years]<br/>- D.Pharm [2 years]</p> | <p><b>After Graduation</b><br/>- M.Pharm [2 years]</p> | <p><b>After Post Graduation</b><br/>- Ph.D</p> |
|---|--|--|

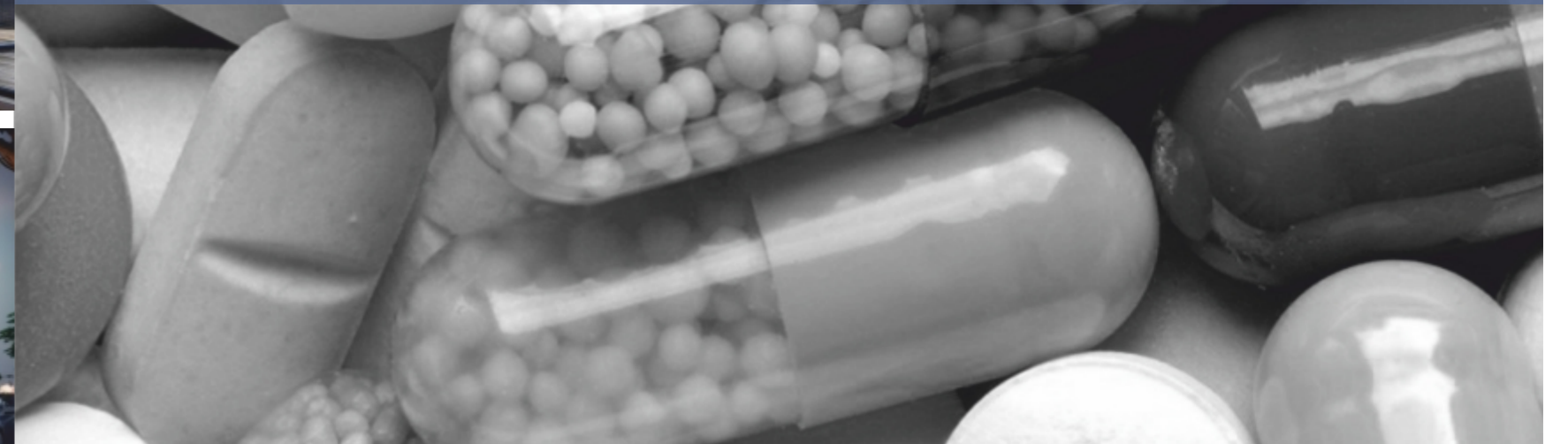

### TIG tops in MAKAUT exams

We, at Techno India Group, are immensely proud of our vibrant student community; over the years, our students belonging to different disciplines such as Engineering, Management etc have performed exceptionally well in MAKAUT semester examinations. Many of our students have also been University gold medal holders of B.Tech in Civil Engineering, Biomedical Engineering, Electrical Engineering, Information Technology, Food Technology, BCA and BBA. The list of medal holders is available at <http://203.200.188.5/convocation/collegewisemedallist.php?parms=322>

### Training program at Germany

Students at Techno India Group are sent for international training programs at Germany where exposure to hands-on training experiences hones their technical and analytical skills. We, at TIG, ensure that our students are well prepared to face the challenges of the corporate and professional world.

### IEEE International Conference

Techno India University, West Bengal organizes the annual International Conference on Computer, Electrical & Communication Engineering (ICCECE) that showcases innovative research contributions in the field of Computing. ICCECE 2024 entailed keynote speeches by eminent professors belonging to the top 5 IITs, ISI and Ivy-League Universities which was the first of its kind in the state of West Bengal. For more details, visit [www.iccece.com](http://www.iccece.com).

All the research publications of ICCECE have been uploaded in the IEEE digital library. Kindly visit <https://ieeexplore.ieee.org/search/searchresult.jsp?queryText=iccece&newsearch=true>

### TIG in Real-time Engineering

The students from Electrical Engineering of TIG volunteered with the faculty to provide Consultancy on the working of the floodlights. They meticulously observed and learned in detail about the mechanism, functioning and maintenance of these lights at the Eden Gardens, Yuva Bharati Krirangan, etc.

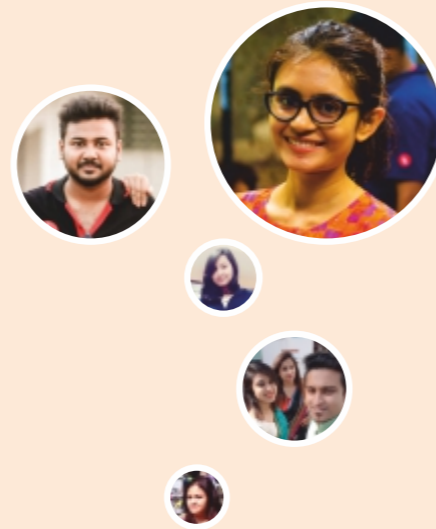

# THE POSTHUMAN MEETS TECHNO INDIA

Techno India Group has made significant advances in the field of education, technology and entrepreneurship. In its 40 years, one of the most significant achievements of the Group was the arrival of Sophia, world's first robot-citizen, developed by Hanson Robotics, to Techno India. In a proud moment for the Techno India Group, the creators of Sophia have used the photos clicked of her at our interactive event to promote and spread the news of this new intervention in the field of Artificial intelligence. We wish to continue to produce such exemplary work in the future.



# INTERNATIONAL JOURNAL

**TIU Transactions in Intelligent Computing (TTIC)**  
[www.tiutic.org](http://www.tiutic.org)

TIU transactions in Intelligent Computing will be a distinguished initiative in the field of Engineering which will serve as an efficient global platform for the academic enrichment of students across the globe. The published journals will be available in both printed and digital form. Two issues will be published in a single year. TTIC will be a unique endeavour in the field of Engineering & Technology.



**TIU Transactions on Human Sciences (TTHS)**  
[www.tthumanscience.org](http://www.tthumanscience.org)

An international journal dedicated to advancing novel frontiers in the field of human sciences, the Techno India University Transactions on Human Sciences publishes peer-reviewed articles focusing on interdisciplinary studies in the human sciences and various domains including Microbiology, Biotechnology, Pharmacy, Psychology, Agriculture, Food Technology, Medical Science, Bioinformatics, Biochemistry, Neuroscience, and more.



(ISSN NO : 3048-4901)



# ANNUAL CONVOCATION CEREMONY



In 2019, 2023 and 2024, Techno India University celebrated its graduates with vibrant Convocation Ceremonies, attended by thousands of students and esteemed thought leaders from across the country. The university had the privilege of hosting the 14th Hon'ble President of India Shri. Ram Nath Kovind as the Chief Guest who delivered the Convocation Speech in 2024. The former President of India, Shri Pranab Mukherjee as well as Padma Vibhushan Shri. N. R. Narayana Murthy have also delivered the Convocation Speech as the Chief Guest previously. Notable figures from various industries and social spheres, including Shri. Shankar Mahadevan, Smt. Shabana Azmi, Shri. Leander Paes, Smt. Arundhati Bhattacharya (former Chairperson of SBI), Shri. Sourav Ganguly, Smt. Sushmita Sen, Padma Vibhushan awardee Shri. Ratan Tata, economist Prof. Vivek Debroy, singer Padma Shri Smt. Kavita Krishnamurthy, author Shri Buddhadeb Guha, singer Pt. Ajoy Chakraborty, writer Shri. Shirshendu Mukhopadhyay, scientist Dr. Tessa Thomas, educationist Shri Sparshamani Chatterjee, Dr. Apurba Ghosh and Dr. Sukumar Mukherjee, have been acknowledged for their significant contributions to society and awarded the prestigious D.Litt degree (Honoris Causa).

# TIG TODAY



## SAP University Alliances

Techno India Group is associated with a global program that promotes the integration of latest SAP technologies into teaching-SAP University Alliances. By exposing students to a wide range of SAP software and curriculum, students get an enormous opportunity to better connect business and IT concepts, thus paving way for the next generation of developers, data scientists and entrepreneurs. Such exposure is of paramount importance towards building strong professional careers in this day and age.

## Virtual Reality Lab

Techno India Group firmly believes in imparting knowledge about state-of-the-art technologies to keep the students informed of revolutionary and promising innovations. Aspirants are encouraged to explore the Virtual Reality laboratory that has been established in the campus premises to ensure that they embrace the opportunities created by this technology and further exploit them for research studies.



## International Students

Techno India Group has earned its well-deserved reputation in the field of academics and education by virtue of its state-of-the-art infrastructure, world-class amenities and industry driven curricula framed in collaboration with eminent universities and industries. Its unique academic endeavors and initiatives have attracted international students from every corner of the world including Nepal, Bangladesh, Bhutan, Ghana, Togo, Thailand and Nigeria. The dedicated department for international students at TIU, WB guides them through the entire admission process including Visa application and accommodation.



## Nanotechnology Lab

The Nanotechnology lab established within the TIG premises is operating under the skilled guidance of Prof. Dey, IIT Kharagpur. Students have been immensely inspired and motivated to be able to work under his expertise and mentorship.

## Seminars and Workshops

Seminars and workshops play a predominant role in efficiently grooming students at Techno India Group. Seminars allow industry professionals, academicians and field experts to exchange ideas under one umbrella and also discuss about the relevant advancements in various academic fields. Workshops inculcate proper problem solving, strategic and technical skills in students that prepares them to handle corporate assignments and soak in the professional ambience. Such endeavors broaden the vision of the aspirants here, motivating them to envision a better world for times ahead.

## Orientation Programme

At the start of their academic journey, students at the Techno India Group undergo an orientation programme where they are introduced to the ins and outs of college life and how it is different from Higher Secondary education. Thought leaders, spiritual thinkers and academic researchers address the incoming batch of students guiding them towards the path which shall bring them the maximum amount of success in their academic journey.

## Teaching and Supervision

In order to ensure that students get hassle-free access to study materials anytime and anywhere, Techno India Group provides tutorial classes and e-learning portals; access to these repositories allow aspirants to go through the concerned study resources without being physically present in the class. If students are unable to attend classes on a particular day due to viable reasons, the prerecorded video lectures in the portal ensure that they do not miss out on the class lectures. Mock test portals and soft skill development sessions prepare students to face campus interviews by providing them with a mock corporate exposure. Appearing for these mock tests assuages their uneasiness while conversing with interviewers of premier industries. Techno India Group does not intend to leave any stone unturned when it comes to providing the apt grooming and guidance to its students.



# EDUCATION Through Innovation



Techno India Group honors the achievements of its students including the national and international award winners. Over the years, our students have been performing exceptionally well in various inter-collegiate competitions which bear witness to the exceptional standards of this elite group. Their phenomenal achievements have attracted media attention as well.

## Centre for Interdisciplinary Innovation

The Centre for Interdisciplinary Innovation (CII) at Techno India University draws on the talents of enthusiastic undergraduates, specialized postgraduates, and research-driven doctoral scholars to generate unique solutions to pressing industry problems. Experienced academics and industry professionals provide knowledge and practical insights, ensuring the Cell's work is oriented around industry requirements.

This hub fosters collaboration beyond traditional boundaries to tackle industry challenges. Its goals are to identify and solve pressing problems, implement practical solutions, promote cross-disciplinary collaboration, engage in industrial projects and product development, and bridge the gap between academia and industry.

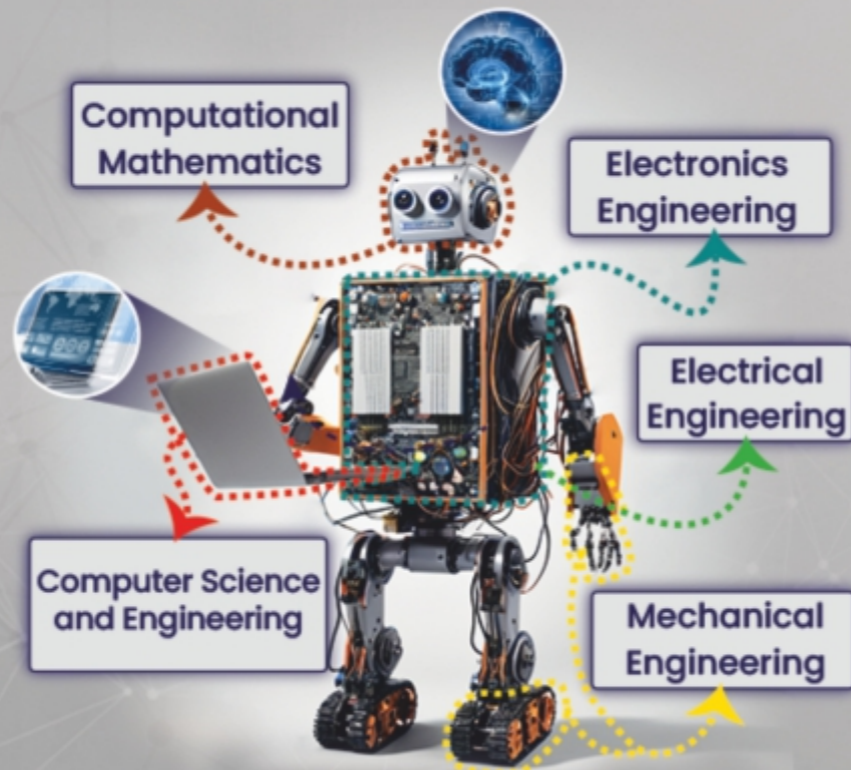

## Best at Innovation

Techno India Group has earned nationwide recognition on account of its outstanding research infrastructure and innovative endeavors. Sowing the seeds of unconventional research methodologies and one-of-a-kind academic initiatives has been one of the prime objectives of this group right from the start. This has arrested the attention of media several times.

## "TCS 100 Best Students in India" award

Techno India Group is immensely proud of Subhajit Basak, B.Tech (ECE) of Techno India Salt Lake, for receiving the TCS 100 best students' award. This prestigious award being received by one of our students has definitely been a feather in our cap.



## Smart Bag

Students of Techno India University, West Bengal recently designed Smart Bag- a unique innovation developed on Android platform. Aiming to provide high level security to users in the age of cyber crimes and security threats, such an innovation is priceless indeed.

## National Innovation Challenge Design

Students of Techno India Group have performed exceptionally well in the National Innovation Challenge Design contest organized by Texas Instruments held at Delhi. Achievements such as these showcase the true potential and creativity of our students.



## PEGA

Built on the Pega platform, Pegasystems is a reputed American software company that builds applications to meet strategic business needs. Techno India University, West Bengal is a member of Pega University academic program.

## Double Decker Airport Design & Underground Tube Tunnel Design

The world's first double decker airport being designed by Architecture & Civil Engineering departments of Techno India Group is a milestone in the field of innovation. An underground tube tunnel connecting river Ganges is also such a cumulative endeavor by the above departments which is presently being planned and will be actualized soon.

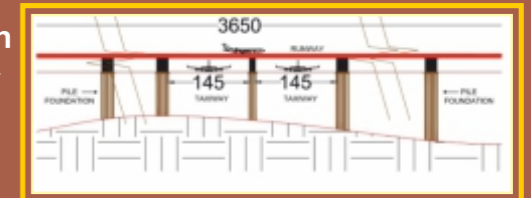

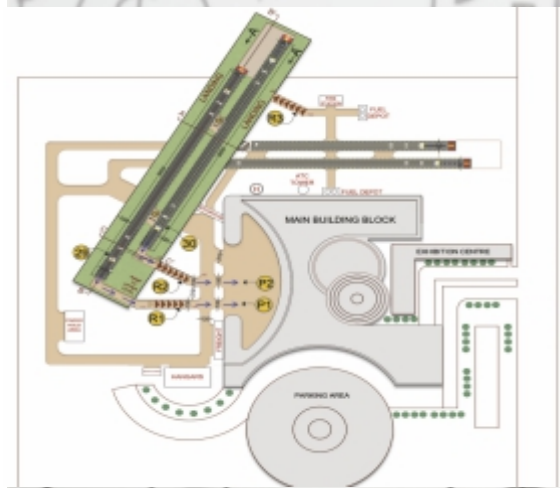
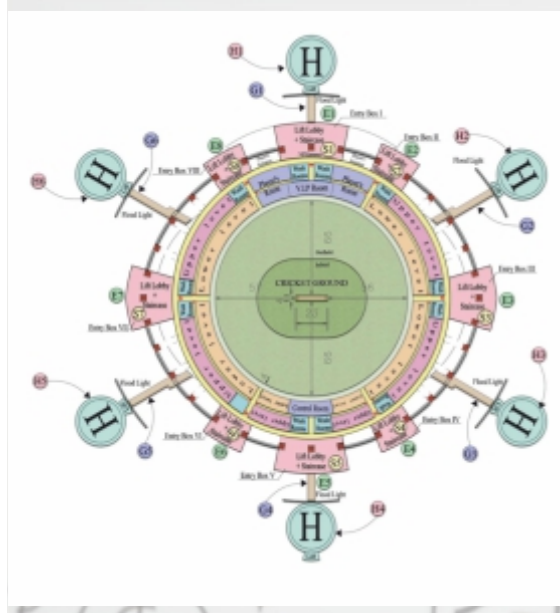
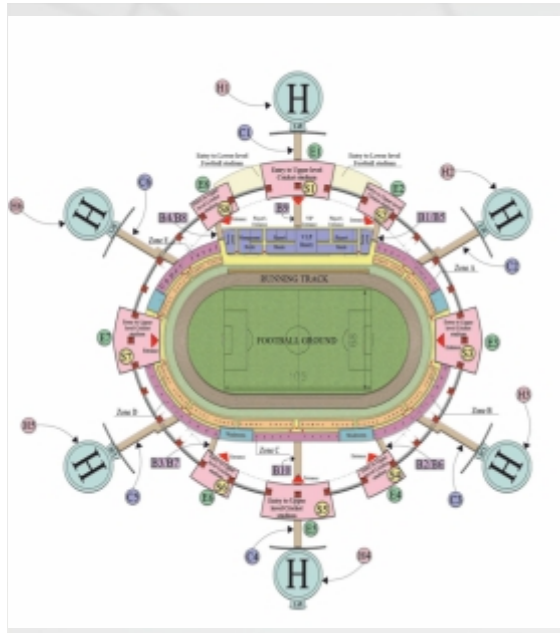

# EDUCATION THROUGH INNOVATION

At Techno India University, we place a significant emphasis on the vital role that application-based research plays in advancing knowledge and solving real-world challenges. We believe that fostering a dynamic and innovative research environment is key to pushing the boundaries of what is possible. Currently, TIU has undertaken numerous groundbreaking projects across various departments, particularly in Architecture and Civil Engineering. These efforts have culminated in the filing of several patents for revolutionary concepts such as the world's first double-decker airport, a multi-layered stadium that redefines space utilization, and a cutting-edge projectile system designed to process waste at an interplanetary level. Furthermore, our research extends into the realm of Artificial Intelligence, where we are pioneering AI-informed agricultural practices that promise to transform the industry. Additionally, our university has developed a novel concept for a multi-layer burial ground, reflecting our commitment to sustainable and forward-thinking solutions.

These pioneering research initiatives are not just theoretical; they provide our students with the tools and opportunities to tackle some of the most pressing challenges facing industries today. By engaging directly with these complex problems, our students develop practical skills and innovative mindsets that are essential for success in their future careers. At TIU, we are not only preparing students to excel in their chosen fields, but we are also cultivating the next generation of academics, innovators, and thought leaders who will shape the future.

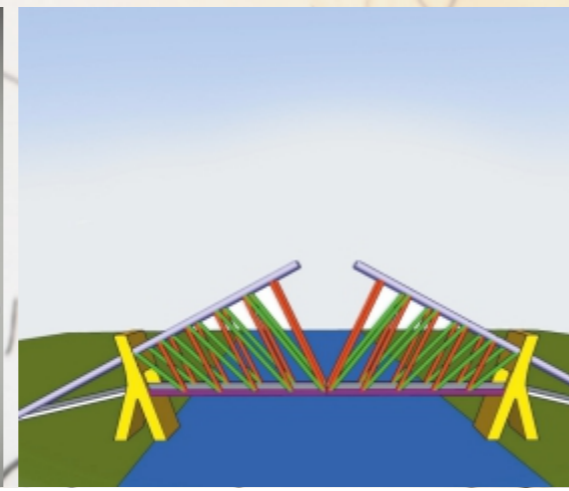
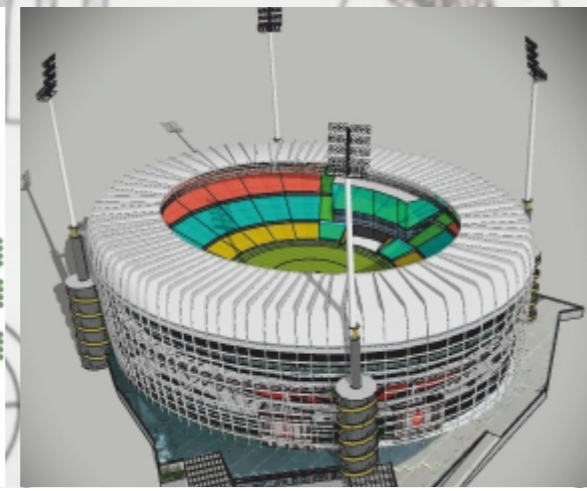

"In the realm of education and industry, the integration of emerging technologies and artificial intelligence is not merely an enhancement but a transformation. It equips our students and professionals with tools that not only foresee change but drive it, ensuring our progress is not just current but ahead of the curve." - Prof. G. Roy Chowdhury, Chairman, Techno India Group

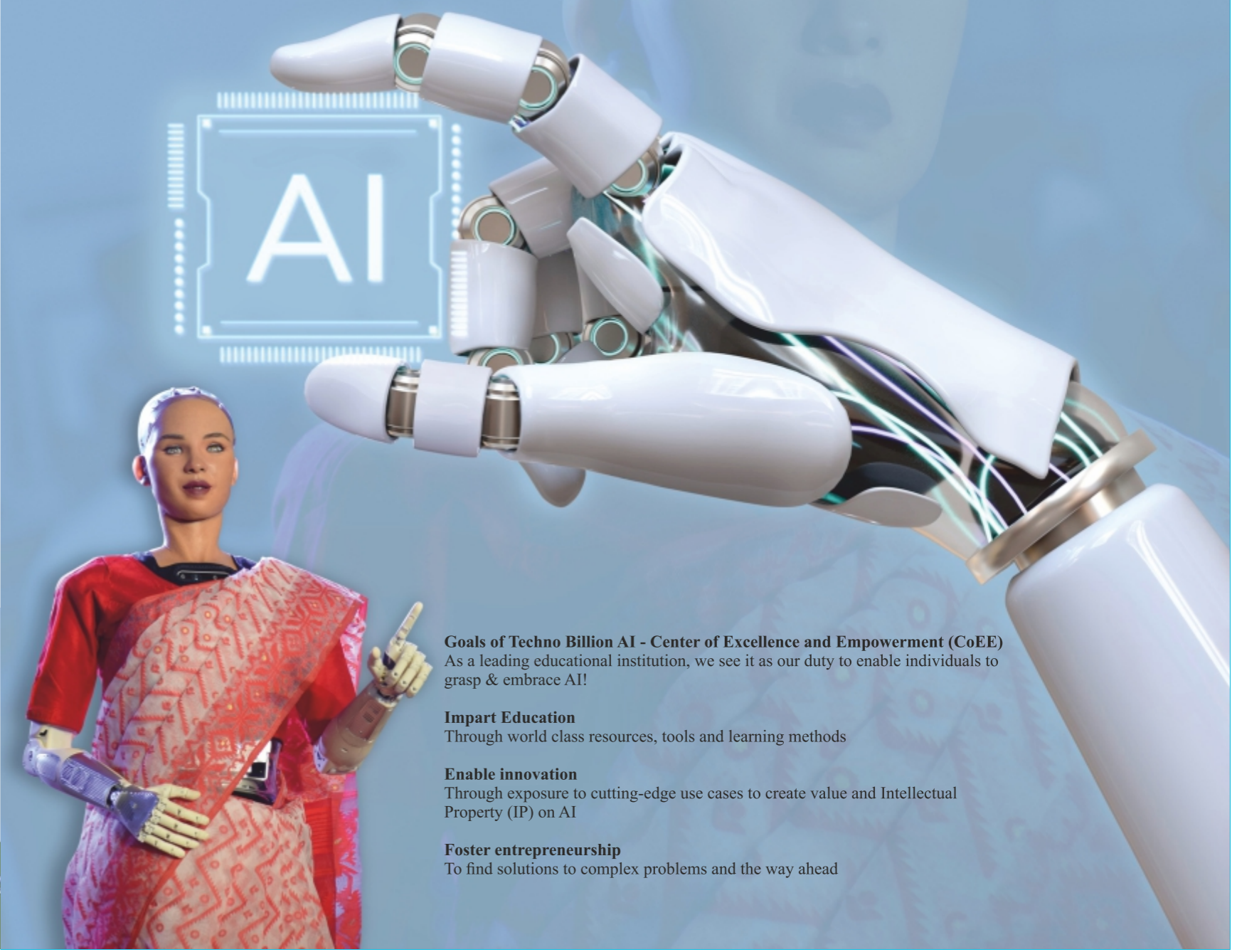

**Goals of Techno Billion AI - Center of Excellence and Empowerment (CoEE)**  
As a leading educational institution, we see it as our duty to enable individuals to grasp & embrace AI!

**Impart Education**  
Through world class resources, tools and learning methods

**Enable innovation**  
Through exposure to cutting-edge use cases to create value and Intellectual Property (IP) on AI

**Foster entrepreneurship**  
To find solutions to complex problems and the way ahead

Engineering Physics Lab  
 Electrical Engineering Lab  
 Engineering Graphics  
 Workshop Practical  
 Engineering Chemistry Lab  
 Computing Lab  
 Electronics Engineering Lab  
 Engineering Graphics  
 Numerical methods Lab  
 Biophysical Signals & Systems Lab  
 Circuits & Networks Lab  
 Physiology Lab  
 Analog Electronic Circuits Lab  
 Communication skill & Report writing  
 Biophysics & Biochemistry Lab  
 Biosensors & Transducers Lab  
 Digital Electronics & Integrated Circuits Lab  
 Biomedical Instrumentation Lab  
 Biomedical Equipments Lab 0  
 Communication Engineering Lab  
 Data Structure & C Lab Object Oriented Programming &  
 JAVA Lab Computer Organization Lab  
 Android Lab  
 Python Lab  
 Medical Instruments Lab  
 Biomedical Digital Signal Processing Lab  
 Microprocessor & Microcontroller Lab  
 VLSI Design Lab  
 Biomaterials & Biomechanics Lab  
 Biomedical Instruments & System Lab  
 Medical Image Processing Lab  
 Adaptive Signal Processing Lab  
 Design Lab / Industrial problem related practical training  
 Basic Environmental Engineering & Elementary Biology Lab  
 Basic Science Chemistry  
 Professional Core Biochemistry Lab  
 Professional Core Microbiology Lab  
 Technical Report Writing & Language Lab Practice  
 Engg. Sc. Numerical Methods  
 Engg. Sc. Transfer Operation  
 Core Molecular Biology Lab  
 Core Fermentation Technology Lab  
 Genetics Lab  
 Core Bioinformatics Lab  
 Elec Transfer operation Lab  
 Elec. Data Structure & Algorithm Lab  
 Recombinant DNA Technology Lab  
 Core. Immunology Lab  
 Elec Plant Biotechnology Lab  
 Elec. Data Base Management System and Computer  
 Networking Lab  
 Group Discussion  
 Core. Bioreactor Design & Analysis Lab  
 Elec. Food Biotechnology Lab  
 Elec. Process Instrumentation & Control Lab  
 Design Lab /Industrial problem/ Industrial related training  
 Physics  
 Solid Mechanics  
 Surveying Practice  
 Building Design & Drawing  
 Technical Report Writing & Language Lab  
 Practice Numerical Methods  
 Fluid Mechanics  
 Surveying Practice  
 Soil Mechanics Lab  
 Concrete Laboratory  
 Quantity Surveying, Specifications and Valuation  
 Engineering Geology Laboratory  
 Highway & Transportation Engg Lab  
 Detailing of RC and Steel Structures  
 CAD Laboratory  
 Environmental Engg Lab  
 Civil Engineering Practice Sessional  
 Elective Laboratory  
 Industrial Training  
 Structural Engineering Design Practice  
 Analog & Digital Electronics  
 Data Structure & Algorithm Computer Organisation  
 Analog & Digital ElectronicsData Structure & Algorithm  
 Computer Organisation  
 Physics Lab  
 Technical Report Writing & Language Lab Practice  
 Communication Engineering & Coding Theory  
 Software Tools Computer Architecture  
 Design & Analysis of Algorithm Microprocessors &  
 Microcontrollers  
 Programming Practices using C++ Circuit Theory & Network  
 (ECE)

# Laboratories

Techno India Group provides state-of-the-art research infrastructure owing to which this academic group has created a repute of its own in the field of academics. Well equipped research laboratories with top notch facilities serve as an added boon for the aspirants which help them in exploring their subjects to a greater depth.

Data Communication (ECE)  
 Digital Signal Processing (ECE)  
 Object Oriented Programming (IT)  
 Data Base Management System Lab  
 Network Lab  
 Operating System Lab  
 Software Engineering Lab  
 Pattern Recognition  
 Soft Computing  
 Artificial Intelligence  
 Image Processing  
 Internet Technology (IT)  
 Microelectronics & VLSI Design (ECE)  
 Control System (EE)  
 Modelling & Simulation (M)  
 Design Lab / Industrial problem related practical training  
 (Workshop needed)  
 Analog & Digital Electronic circuit  
 Numerical Methods  
 Electric Circuit Theory  
 Technical report writing and language practice  
 Total of Practical / Sessional  
 Physics-II Lab  
 Transducers & sensors Lab  
 Electric Machine Lab  
 Electrical & Electronic measurement Lab  
 Total of Practical / Sessional  
 Electric machine  
 Digital Signal Processing  
 Data structure & algorithm  
 Computer Organization  
 Microprocessor & Microcontroller  
 Seminar  
 Total of Practical / Sessional  
 Power System  
 Control System  
 Power Electronics  
 Operating System  
 Object Oriented Programming & JAVA  
 Embedded Systems  
 Total of Practical / Sessional  
 VLSI design  
 Digital Communication & Network  
 Operating system  
 Embedded system  
 AI & soft computing  
 Design of Electrical / Electronic Systems  
 Seminar on industrial training.  
 Project  
 Electrical Systems Laboratory  
 Grand Viva 3 Total of Practical / Sessional  
 Analog & Digital Electronic circuit  
 Numerical Methods  
 Electric Circuit Theory  
 TECHNICAL REPORT WRITING & LANGUAGE  
 LABORATORY PRACTICE  
 Physics Lab  
 Thermal power Engineering Lab  
 Electric Machine  
 Electrical & Electronic measurement  
 Total of Practical /Sessional  
 Electric machine  
 Power system

Control system  
 Data structure & algorithm  
 Computer Organization  
 Micro Processor & Microcontroller  
 Control System  
 Power System  
 Power Electronics  
 Software Engineering  
 Data Base Management System  
 Object Oriented Programming  
 Embedded Systems  
 Seminar on industrial training  
 Electric Drive  
 Computer Network  
 AI & Soft Computing  
 Digital Communication  
 Digital Image Processing  
 Electrical system design  
 Environmental Engineering Lab  
 Chemistry of Food Lab  
 Food Microbiology Lab  
 Biochemistry Lab  
 Chemistry of Food Lab  
 Unit operation Lab  
 Numerical methods lab  
 Technical Report Writing & Language Lab Practice  
 Food processing lab  
 Food analysis & quality control lab  
 Unit operation lab  
 Food processing lab  
 Microbial technology lab  
 Data structure & algorithm lab Seminar  
 Group Discussion  
 Food Engineering lab  
 Report and Seminar on Industrial Training  
 Instrumentation & Control Lab Sessional  
 Product Development & Quality Assurance Lab  
 Technical Report Writing & Language Lab  
 Practice Physics Lab  
 Machine Drawing  
 Workshop Practice  
 Applied Mechanics Lab  
 Numerical Methods Lab  
 Fluid Mechanics & Hydraulics Lab  
 Manufacturing Technology Lab  
 Material Testing Lab  
 Machine Drawing  
 Applied Thermodynamics & Heat Transfer Lab  
 Design Practice  
 Metrology & Measurement Lab  
 Professional Elective Lab-I  
 Machining & Machine Tools Lab  
 IC Engine Lab  
 Design Practice  
 Dynamics of Machines Lab  
 Professional Elective Lab  
 Advanced Manufacturing Lab  
 Design of a Mechanical System  
 Seminar  
 Ppt preparation on a topic of interest  
 Project  
 Viva Voce  
 Group Discussion  
 PEGA Lab

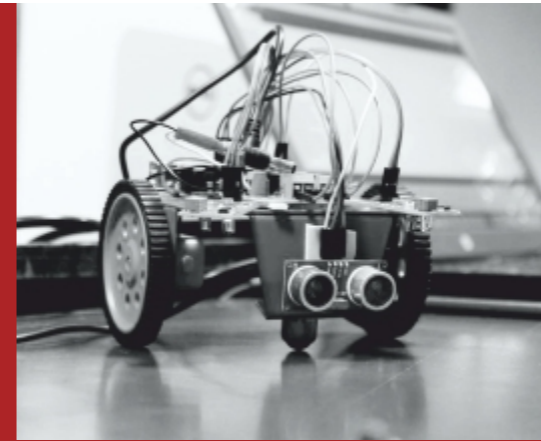

Agricultural Bioengineering Lab  
 Soil Science Lab  
 Agriculture Engineering Structures & Rural Engineering Lab  
 Farm Machinery Lab  
 Architectural Design  
 Creative Expressions  
 Nss/ Eca/ncc/ Sports  
 Architectural Design –ii  
 Methods Of Construction  
 Workshop Practice - I  
 Educational Tour  
 Architectural Design –iii  
 Methods Of Construction - ii  
 Rendering Techniques  
 Architectural Design –iv  
 Methods Of Construction - iii  
 Computer Graphics -I  
 Workshop Prac Ii  
 Educational Tour  
 Architectural Design – V  
 Methods Of Const -iv  
 Comp Graphics –ii  
 Materials Testing Wk Shp  
 Architectural Design – Vi  
 Working Drawings  
 Survey Field Work  
 Educational Tour  
 Architectural Design – Vii  
 Interior Design  
 Architectural Design - Viii  
 Thesis Programming  
 Critical Appraisal  
 Documentation Of Innovative Details  
 Field Observation  
 Office Training  
 Site Supervision  
 Architectural Thesis  
 Pharmaceutical Analysis Lab  
 Pharmaceutics (dispensing Pharmacy) Lab  
 Pharmaceutical Chemistry Lab  
 Remedial Biology Lab  
 Pharmaceutical Chemistry (physical Chemistry) Lab  
 Pharmaceutical Chemistry (organic Chemistry) Lab  
 Pharmacognosy Lab  
 Physiology Lab  
 Pharmaceutical Chemistry (organic Chemistry) Lab - -  
 Pharmaceutical Analysis  
 Pharmaceutics (physical Pharmacy) Lab  
 Engineering Drawing Lab  
 Basic Electronics & Computer Application Lab  
 Pharmaceutics (pharmaceutical Technology-I) Lab  
 Pharmacognosy Lab  
 Pharmaceutical Engineering Lab  
 Pharmaceutics (pharmaceutical Technology-ii) Lab  
 Pharmaceutical Engineering Lab  
 Pharmaceutical Microbiology Lab  
 Pharmaceutical Chemistry (medicinal Chemistry) Lab  
 Pharmaceutical Chemistry (medicinal Chemistry) Lab  
 Pharmaceutics (pharmaceutical Technology) Lab  
 Pharmaceutics (bio-pharmaceutics & Pharmacokinetics) Lab  
 Pharmacology Lab  
 Pharmaceutics (pharmaceutical Technology) Lab  
 Pharmaceutical Chemistry (medicinal Chemistry) Lab  
 Pharmaceutical Analysis (Pharmacy) Lab  
 AI Lab  
 Machine Learning Lab  
 Deep Learning Lab  
 Linux Processing Lab  
 Laser Communication Lab





## Libraries

Techno India Group provides a well-maintained library which serves as a reservoir of knowledge for students. Filled with a multitude of national and international books and journals which encompass a diverse spectrum of academic streams, students regularly access these resources according to their convenience. The library also maintains archives of students' project reports, relevant case studies, dissertations and conference proceedings. Digital Resources and online journals constituting the digital library enable students to access class notes and study materials even outside their classrooms and library hours. Online repositories comprising international books and research publications help students demystify the concepts in their respective fields of study anytime and anywhere.



In order to cater to the advancements of the present age, Techno India Group includes projects as an integral part of the academic curricula. Students enrolled in the undergraduate courses implement application-oriented projects in collaboration with premier industries. Skilled mentors evaluate their performance and allotted credit points for such projects reflect the proficiency with which the students carry out the assigned tasks. In the post-graduate level, innovative research contributions are highly encouraged. JRFs and SRFs actively participate in international conferences and seminars and publish their research findings in premier journals. Through an abundance of hands-on-training experiences in live platforms, Techno India prepares the aspirants for glorious professional careers ahead.

## Paving the way for Skilled Human Resources

Ever since its inception, Techno India believes in synergy between peer institutes to stay at par with the latest technological advancements and innovations. To further enrich the academic programs, faculty members and professionals from reputed international universities and industries are invited to address students in various workshops and seminars.

Students at TIG receive innumerable national and international level industrial internship opportunities which helps them gain hands-on-training experiences leading to their sharpened problem solving, analytical and strategic skills.

## Placement Team

Techno India Group by virtue of its 40+ glorious years of experience in academia coupled with a vibrant placement team has earned nationwide repute and recognition. Exceptional placement statistics is the major strength of this elite group. An abundance of collaborations and tie ups with industries and foreign institutes has helped Techno India in reaching the peak of excellence.

Every college under Techno India Group has individual placement cells with dedicated placement officers at their disposal. There is a centralized placement team at Techno India Salt Lake where the members regularly monitor every ongoing placement related activity and coordinate with their peers in every unit of TIG to stay informed about the recruitment drive updates.

The placement department of Techno India organizes grooming sessions, soft skill development classes and mock exam interfaces for students to pass with flying colors in the recruitment drives. Techno India leaves no stone unturned in guiding its students towards building a glorious professional future.

## Placement





## Hands on Skill Development for Engineers

Techno India always tries to involve students in hands-on training, besides their theoretical knowledge because engineers should know how to implement their skills in real time. Without execution there is no meaning of good engineering knowledge. Hands-on training in various big industries like stadiums, railways, bridge authorities and flood lights helps them to get the experience to handle difficult situations in professional contexts. If they combine their laboratory work with these big live projects, it builds up their confidence.

## Social Responsibilities

In society, individual growth is not the only growth. Only overall growth helps a country to develop. TIU always believes in inculcating this culture in our students as they are our future leaders to make a well developed India. Right from the graduation level onwards, every student needs to acknowledge the importance of social relationship and the ethical value of human bonding which involves engaging in social practices on a regular basis. For this purpose, all over the state as well as the country we frequently involve our students in cleaning, social health awareness programs, development of the underprivileged, rural development and many such activities. During the festive season, they also help in cleaning up the countryside and extend their help as much as possible. They take the initiative and actively participate in spreading the light of education to the underprivileged children in the rural areas. Our students utilize their leisure time to groom these deprived children and arrange several events to motivate them to continue their education. We have a social responsibility club which has plenty of student members and alumni who even after getting job are actively involved in raising funds for the development of underprivileged children. The club members encourage sponsorships and arrange different events through which the knowledge base of village children is strengthened.



# EXCELLENCE



# BHARAT RATNA SHRI PRANAB MUKHERJEE MERIT SCHOLARSHIP

The Bharat Ratna Shri Pranab Mukherjee Merit Scholarship was officially declared on the 24th of July, 2019 by the former President of India. Techno India University, West Bengal is the first university to take this opportunity to introduce this scholarship and it is a great honour for us. Every year one meritorious student will get this opportunity to receive this scholarship along with a certificate issued by Bharat Ratna Shri Pranab Mukherjee. This scholarship will enable students to concentrate towards increasing their knowledge and skills in the field of Science and Technology to connect India globally.



